



Fastener
Solutions

Screw Cradle Mounts Marketing Specifications

For the following part numbers:

10044-2
10045-2
10046-2
10079-2

August 1, 2018

AVERY DENNISON MARKETING SPECIFICATION

THE SUBJECT MATTER DISCLOSED HEREIN EMBODIES PROPRIETARY INFORMATION WHICH IS THE CONFIDENTIAL PROPERTY OF THE AVERY DENNISON CO. NONE OF WHICH SHALL BE COPIED, REPRODUCED, DISCLOSED TO OTHERS, PUBLISHED OR USED IN WHOLE OR IN PART, FOR ANY PURPOSE OTHER THAN THAT FOR WHICH IT IS BEING MADE AVAILABLE WITHOUT THE EXPRESS ADVANCE WRITTEN PERMISSION OF A DULY AUTHORIZED AGENT OF THE COMPANY. THIS DOCUMENT IS THE PROPERTY OF THE AVERY DENNISON CO. AND IS TO BE RETURNED TO THE COMPANY ON DEMAND.

HISTORY

REV.	DATE	DESCRIPTION
A	2/17/15	RELEASE
B	1/16/18	UPDATE SCREW TYPE

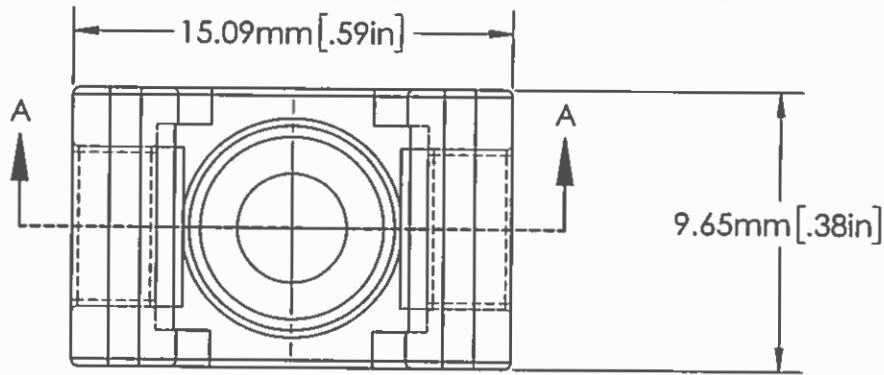

SCALE 4 : 1

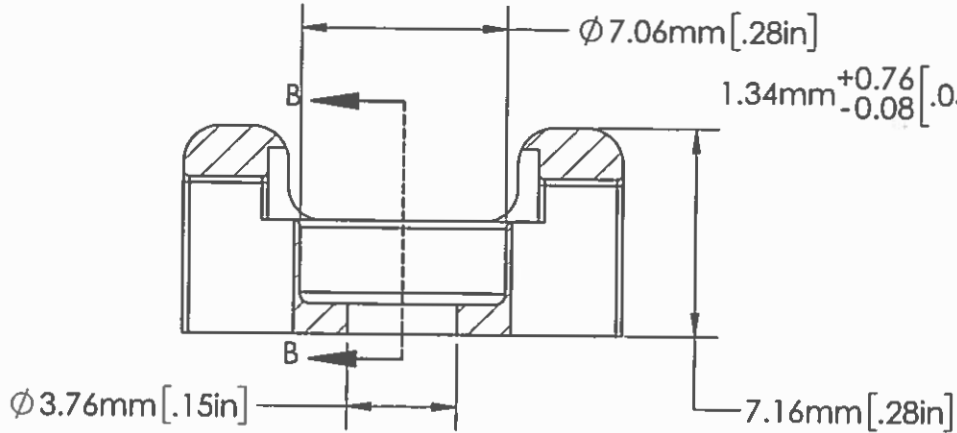

SECTION A-A
SCALE 4 : 1

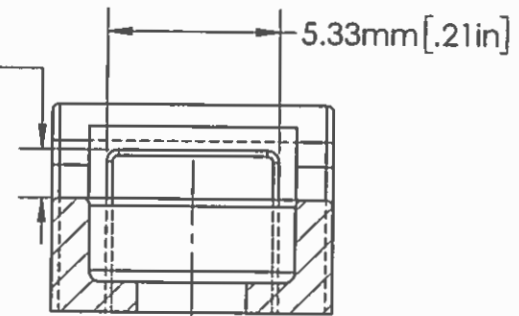

SECTION B-B
SCALE 4 : 1



APPROVALS:	ENG. APPR. <i>Full OK</i> <i>1/6/18</i>	AVERY DENNISON <small>FASTENER DIVISION FITCHBURG, MA 01420 U.S.A. TEL. 1-800-225-5913 FAX. 978-353-8157</small>
	Q.A. APPR. <i>Mark S. ...</i> <i>01/20/18</i>	
SPECIFIED TOLERANCES ARE:		DESCRIPTION
.XX ± .03 INCHES .XX ± .25 MM		CRADLE MOUNT, SMALL
ANGULAR: ± 2°		STOCK NO. 10044-2
MATERIAL NYLON 6/6		REV. B
COLOR NATURAL		

WEIGHT:	.012 oz. / 0.34 grams
MOUNTING:	# 6 (FLAT BOTTOM SCREWS)
PACKAGING:	100/BAG, 5000/CASE

5

4

3

2

1

AVERY DENNISON MARKETING SPECIFICATION

THE SUBJECT MATTER DISCLOSED HEREIN EMBODIES PROPRIETARY INFORMATION WHICH IS THE CONFIDENTIAL PROPERTY OF THE AVERY DENNISON CO. NONE OF WHICH SHALL BE COPIED, REPRODUCED, DISCLOSED TO OTHERS, PUBLISHED OR USED IN WHOLE OR IN PART, FOR ANY PURPOSE OTHER THAN THAT FOR WHICH IT IS BEING MADE AVAILABLE WITHOUT THE EXPRESS ADVANCE WRITTEN PERMISSION OF A DULY AUTHORIZED AGENT OF THE COMPANY. THIS DOCUMENT IS THE PROPERTY OF THE AVERY DENNISON CO. AND IS TO BE RETURNED TO THE COMPANY ON DEMAND.

HISTORY

REV.	DATE	DESCRIPTION
A	2/17/15	RELEASE
B	1/16/18	UPDATE SCREW TYPE

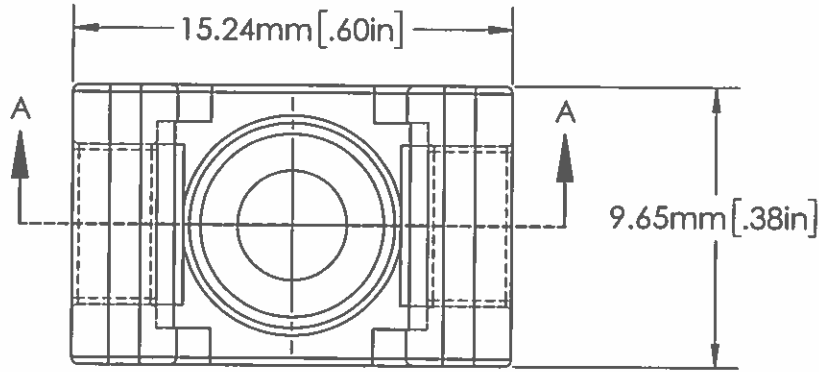

SCALE 4 : 1

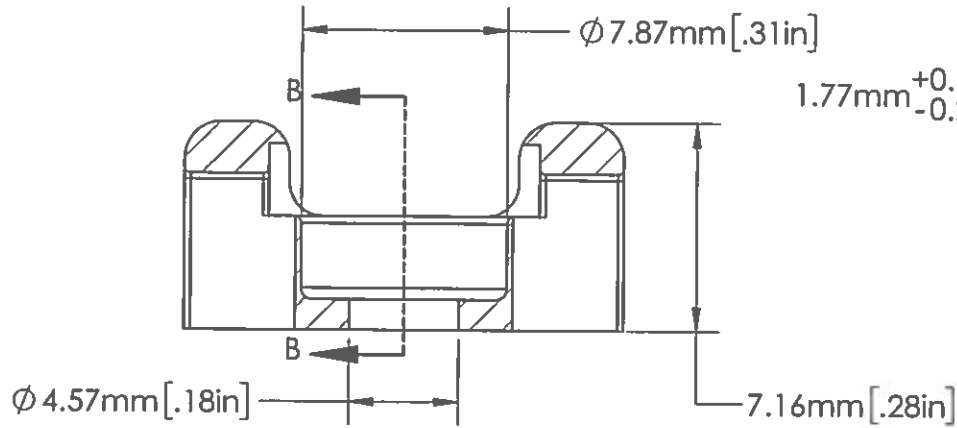

SECTION A-A
SCALE 4 : 1

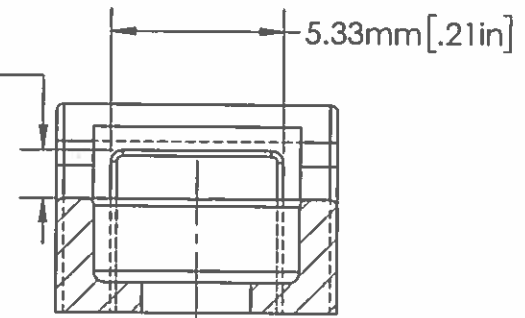

SECTION B-B
SCALE 4 : 1



APPROVALS:	ENG. APPR. <i>ml d2</i> 1/16/18
	Q.A. APPR. <i>Mark S</i> 01/30/2018

AVERY DENNISON
FASTENER DIVISION
FITCHBURG, MA 01420 U.S.A.
TEL 1-800-225-5913
FAX 978-353-8157

WEIGHT:	.034 oz./ .96 grams
MOUNTING:	# 8 (FLAT BOTTOM SCREWS)
PACKAGING:	100/BAG, 5000/CASE

SPECIFIED TOLERANCES ARE:
.XX ± .03 INCHES .XX ± .25 MM
ANGULAR: ± 2°

MATERIAL	NYLON 6/6
COLOR	NATURAL

DESCRIPTION	CRADLE MOUNT, STANDARD	
STOCK NO.	10045-2	REV. B

AVERY DENNISON MARKETING SPECIFICATION

THE SUBJECT MATTER DISCLOSED HEREIN EMBODIES PROPRIETARY INFORMATION WHICH IS THE CONFIDENTIAL PROPERTY OF THE AVERY DENNISON CO. NONE OF WHICH SHALL BE COPIED, REPRODUCED, DISCLOSED TO OTHERS, PUBLISHED OR USED IN WHOLE OR IN PART, FOR ANY PURPOSE OTHER THAN THAT FOR WHICH IT IS BEING MADE AVAILABLE WITHOUT THE EXPRESS ADVANCE WRITTEN PERMISSION OF A DULY AUTHORIZED AGENT OF THE COMPANY. THIS DOCUMENT IS THE PROPERTY OF THE AVERY DENNISON CO. AND IS TO BE RETURNED TO THE COMPANY ON DEMAND.

HISTORY

REV.	DATE	DESCRIPTION
A	2/17/15	RELEASE
B	1/16/18	UPDATE SCREW TYPE

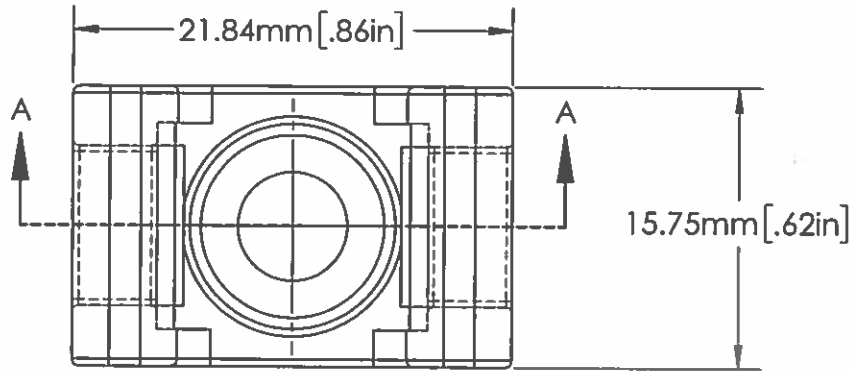

SCALE 4 : 1

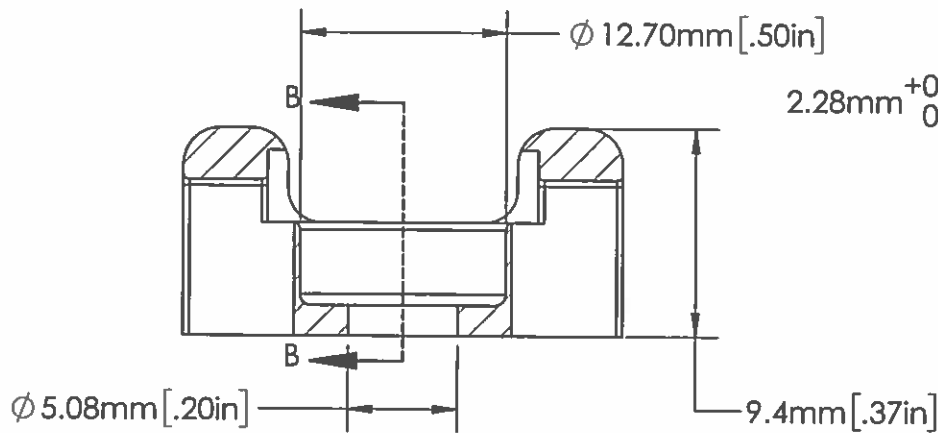

SECTION A-A
SCALE 4 : 1

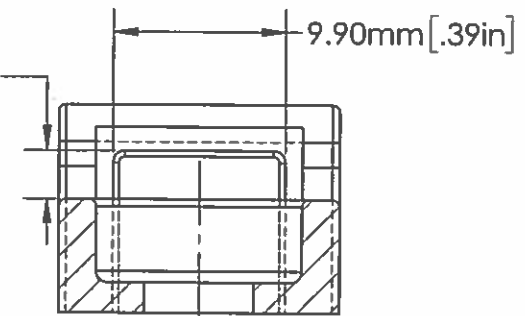

SECTION B-B
SCALE 4 : 1



APPROVALS:	ENG. APPR. <i>Thill</i> 1/16/18
	Q.A. APPR. <i>Stuck</i> 01/30/2018



FASTENER DIVISION
FITCHBURG, MA 01420 U.S.A.
TEL. 1-800-225-5913
FAX. 978-353-8157

WEIGHT:	.071 oz./2.02 grams	SPECIFIED TOLERANCES ARE: .XX ± .03 INCHES .XX ± .25 MM ANGULAR: ± 2°	MATERIAL NYLON 6/6	DESCRIPTION CRADLE MOUNT, HEAVY DUTY
MOUNTING:	# 10 (FLAT BOTTOM SCREWS)		COLOR NATURAL	STOCK NO. 10046-2
PACKAGING:	100/BAG, 5000/CASE			

5 4 3 2 1

AVERY DENNISON MARKETING SPECIFICATION

THE SUBJECT MATTER DISCLOSED HEREIN EMBODIES PROPRIETARY INFORMATION WHICH IS THE CONFIDENTIAL PROPERTY OF THE AVERY DENNISON CO. NONE OF WHICH SHALL BE COPIED, REPRODUCED, DISCLOSED TO OTHERS, PUBLISHED OR USED IN WHOLE OR IN PART FOR ANY PURPOSE OTHER THAN THAT FOR WHICH IT IS BEING MADE AVAILABLE WITHOUT THE EXPRESS ADVANCE WRITTEN PERMISSION OF A DULY AUTHORIZED AGENT OF THE COMPANY. THIS DOCUMENT IS THE PROPERTY OF THE AVERY DENNISON CO. AND IS TO BE RETURNED TO THE COMPANY ON DEMAND.

HISTORY

REV.	DATE	DESCRIPTION
A	2/17/15	RELEASE
B	1/16/18	UPDATE SCREW TYPE

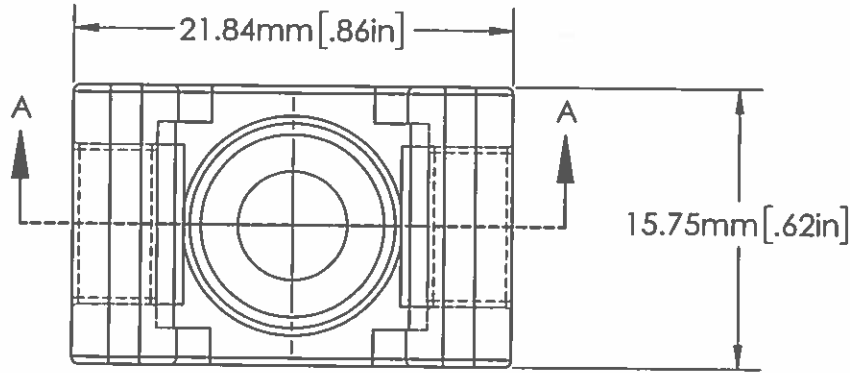

SCALE 4 : 1

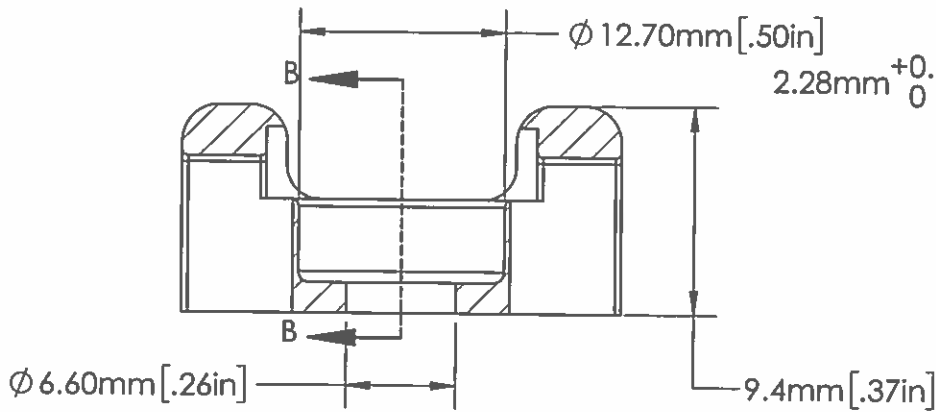

SECTION A-A
SCALE 4 : 1

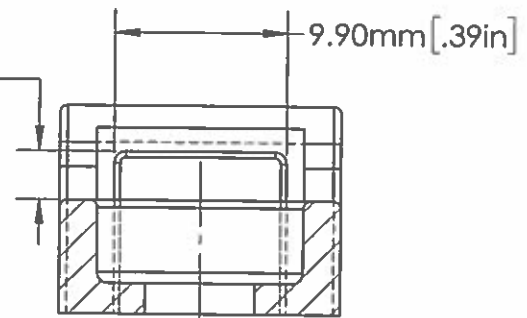

SECTION B-B
SCALE 4 : 1



APPROVALS:	ENG. APPR. <i>[Signature]</i> 1/16/18
	Q.A. APPR. <i>[Signature]</i> 01/20/2018

AVERY DENNISON
FASTENER DIVISION
 FITCHBURG, MA 01420 U.S.A.
 TEL. 1-800-225-5913
 FAX. 978-353-8157

WEIGHT: .071 oz./2.02 grams	SPECIFIED TOLERANCES ARE: .XX ± .03 INCHES .XX ± .25 MM ANGULAR: ± 2°	MATERIAL NYLON 6/6, BLACK HS	DESCRIPTION CRADLE MOUNT, HEAVY DUTY BLACK, HS	
MOUNTING: 1/4" (.25) (FLAT BOTTOM SCREWS)		COLOR BLACK	STOCK NO. 10079-2	REV. B
PACKAGING: 100/BAG, 5000/CASE				

5 4 3 2 1